

## Etanorm / Etanorm R – Standardised Water Pumps

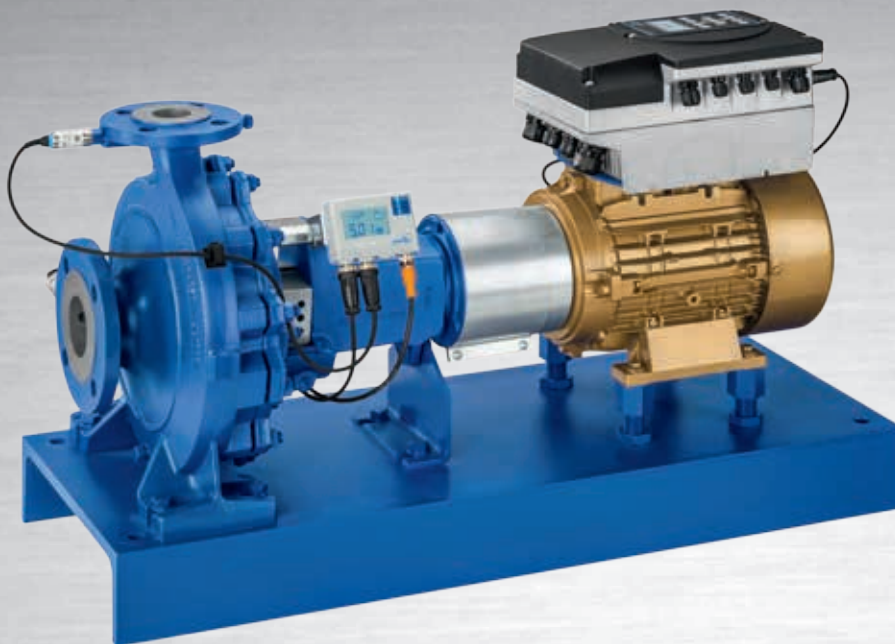

### Applications:

Pump for handling clean or aggressive fluids not chemically and mechanically aggressive to the pump materials.

- Water supply systems
- Cooling circuits
- Swimming pools
- Fire-fighting systems
- General irrigation systems
- Drainage systems
- Heating systems
- Air-conditioning systems
- Spray irrigation systems

### More information:

[www.ksb.com/products](http://www.ksb.com/products)

Etanorm with PumpMeter, KSB SuPremE® motor and PumpDrive



Etanorm with PumpMeter and IE3-motor



Etanorm R

# Etanorm / Etanorm R – Standardised Water Pumps

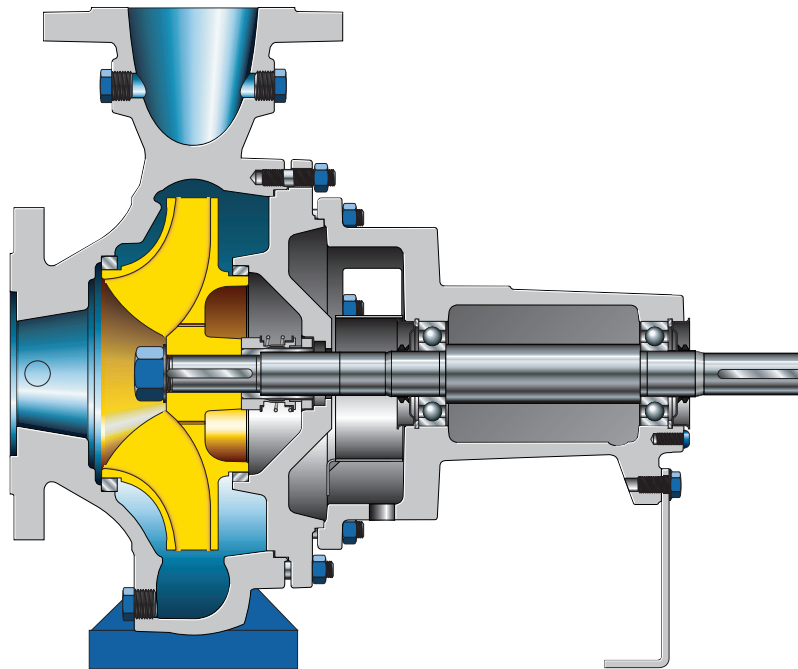

- High energy efficiency**  
Optimised and tested hydraulic system of high efficiency. As a standard, the impellers are trimmed to the operating point.
- Ground-breaking features for saving energy**  
Equipped with PumpDrive for variable-speed operation. When used in combination with the KSB SuPremE® motor, the pump achieves the efficiency level IE4 to IEC/CD 60034-30 Ed. 2 already today.
- Operating reliability**  
Good suction performance for low vibration levels and very smooth running.
- Versatile**  
Great choice of materials for many applications available as a standard.
- Diversity of variants**  
Additional sizes for small flow rates extend the already diverse range of selection charts.
- Service-friendly**  
Fast delivery of new pumps and spare parts. Easier to assemble and dismantle thanks to the larger seal chamber and forcing screws between the casing cover and bearing bracket.

Material variants	Etanorm	Etanorm R
Grey cast iron EN-GJL-250 / A 48 CL 35B	■	■
Nodular cast iron EN-GJS-400-15/A536 GR 60-40-18	■	–
Stainless steel 1.4408 / A743 Gr CF8 M	■	■
Bronze CC480K-GS/B30 C90700	■	–
Nodular cast iron JS1025	–	■

Technical data	Etanorm	Etanorm R
Flow rate	Up to 640 m <sup>3</sup> /h (50 Hz) Up to 740 m <sup>3</sup> /h (60 Hz)	Up to 1900 m <sup>3</sup> /h (50 Hz) Up to 2300 m <sup>3</sup> /h (60 Hz)
Head	Up to 160 m (50 Hz) Up to 160 m (60 Hz)	Up to 101 m (50 Hz) Up to 106 m (60 Hz)
Fluid temperature	-30 °C to +140 °C	
Pressure	Up to 16 bar	



KSB Aktiengesellschaft  
Johann-Klein-Straße 9  
67227 Frankenthal (Germany)  
www.ksb.com