

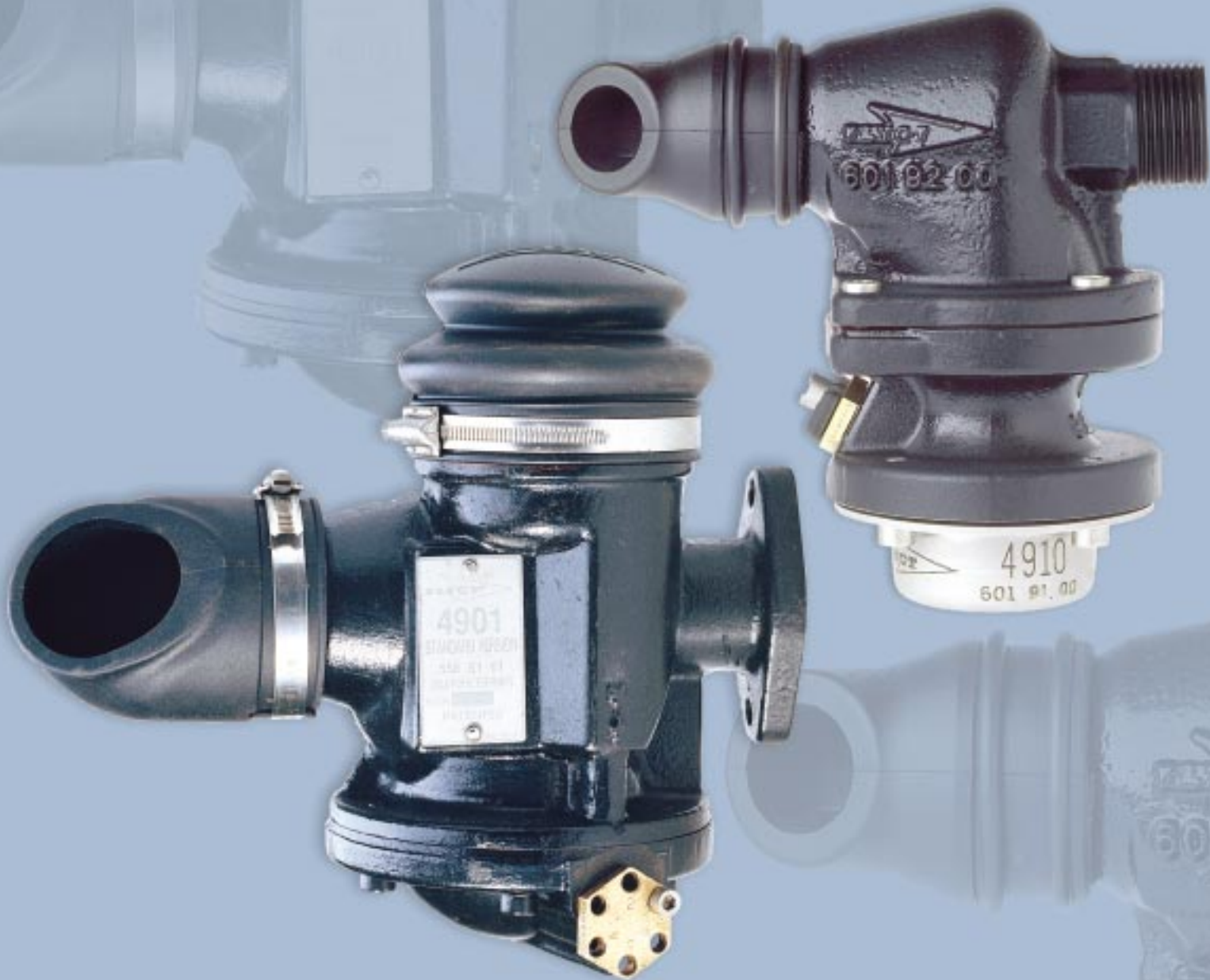

Flush Valves 4901, 4910

Automatic sump desludging



Flygt



Automatic and continuous sump desludging

If grease and solids are permitted to build up in pump sumps, they can cause more than just an unpleasant smell. The pump's level regulators can become fouled, reducing operational efficiency and pump life. Flooding may occur. Regular desludging is therefore essential – and that means downtime and labour costs where mechanical desludging is used.

ITT Flygt's Flush Valve provides a simple, effective and fully automatic way of continuously keeping pump sumps free of sludge by flushing the sump at the beginning of every pumping cycle. Sedimentation in the sump is greatly reduced, and unpleasant odours in and around the pumping station are virtually eliminated.



When the pump starts, the valve opens for approximately 30 seconds, shooting out a powerful jet stream that flushes all solids into suspension, ready to be pumped away.

Because the flushing sequence is an integral part of the pumping cycle, flushing occurs every time the pump starts.

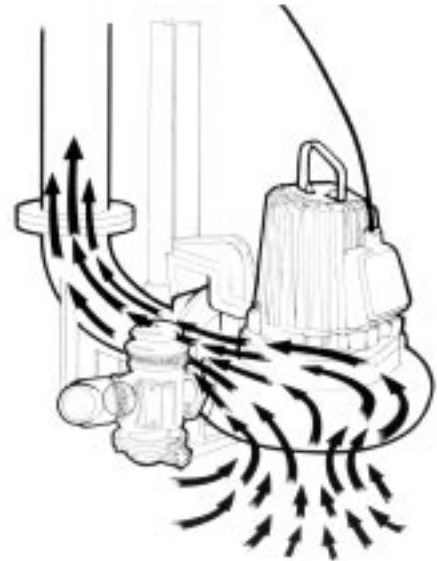

How it works



When the pump starts, the valve is open. The jet stream passing through the valve creates a negative pressure in the ball chamber relative to the pressure in an oil-filled chamber beneath the membrane.



During the next 20 seconds, the ball is lifted by the membrane as the pressure in the two chambers equalises. The time this takes can be varied by regulating the oil flow from the oil reservoir to the chamber beneath the membrane.

Turns a pump into a powerful mixer

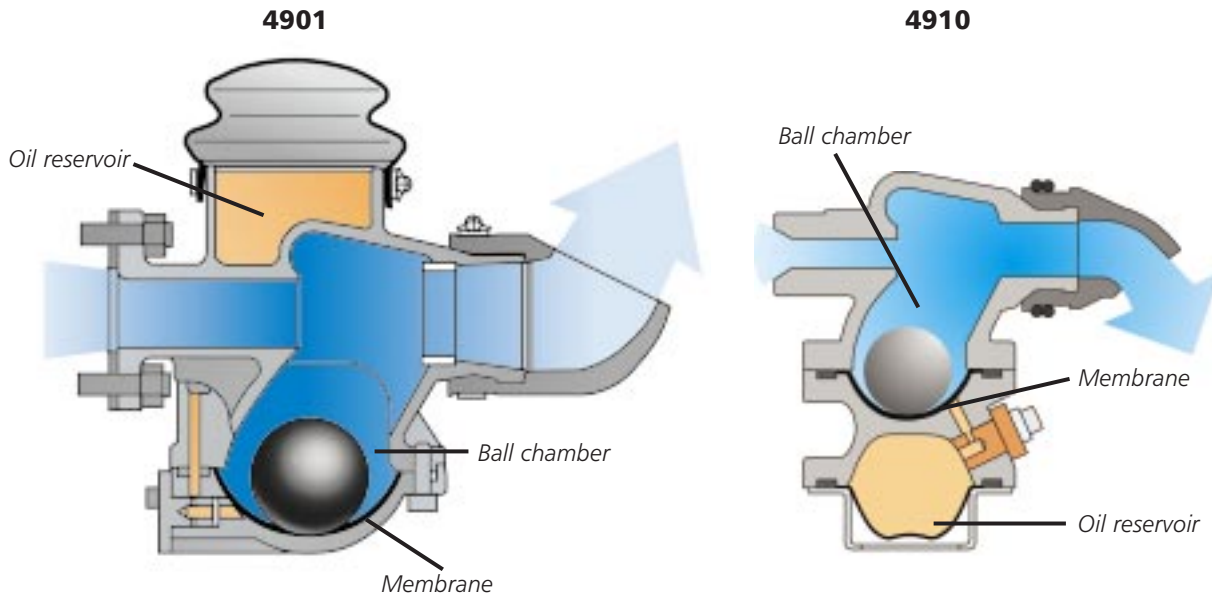

Fitting a Flush Valve harnesses the power of the pump to which it is fitted, creating an automatic flushing system that requires no additional power source. At the beginning of each pumping cycle, the valve is open, concentrating the power of the pump into a jet of water that flushes the sump. As a result, the contents of the sump are subjected to intense agitation, turning the pump momentarily into a powerful mixer. This re-suspends any sludge before the Flush Valve shuts off and the full power of the pump is again focused on pumping wastewater and the suspended solids out of the station. This unique

system also ensures a high degree of oxygenation, which helps to practically eliminate malodorous hydrogen sulphide.

The Flush Valve can be easily fitted to the volute of any CP, DP or NP pump. Fitting just one Flush Valve in a wastewater pumping station less than 6.9 ft in diameter eliminates the need for regular manual desludging. The result is significant savings in operation and maintenance costs, and much improved pumping efficiency.



The ball reaches a critical position and is forced by the jet stream into its seat, thus shutting off the valve. The power of the pump is now fully concentrated on draining the sump, and the pressure inside the valve presses the membrane back into its starting position.



When the pump stops, the pressure inside the valve is released and the ball falls back to its resting position. The valve is now open and ready for the next cycle.

Technical Data



4901



4910

General:	Flush Valve 4901 fits most pumps, and can be retrofitted to all existing CP/NP 3085-3301 and DP 3085-3152 pumps.	Flush Valve 4910 fits all grinder pumps, and can be retrofitted to all existing grinder pumps M 3068-3127.
Length of flushing cycle:	Recommended: 20 seconds. Max. 50 seconds	Recommended: 20 seconds. Max. 50 seconds
Weight:	17.64 lb	5.73 lb
Ambient temperature:	104 F° max	104 F° max
Materials:	Valve body: Cast iron Ball: Cast iron or polyurethane Membranes: Nitrile rubber Oil: Rapeseed oil	Valve body: Cast iron Ball: Ball bearing steel Membranes: Nitrile rubber Oil: Rapeseed oil

Keep your station in top form

The Flush Valve is just one example of how ITT Flygt can improve the cost-efficiency of a pumping station by keeping it cleaner and thus more reliable. Ask your ITT Flygt representative for more information about the following.

ITT Flygt Corporation

35 Nutmeg Drive, P.O. Box 1004, Trumbull, CT 06611
(203) 380-4700

Regional Offices

2330 Yellow Springs Road, Malvern, PA 19355 • Tel. (610) 647-6620
78K Olympia Avenue, Woburn, MA 01810 • Tel. (781) 935-6516
7 Marway Drive, Rochester, NY 14624 • Tel. (716) 426-0280
790-A Chadbourne Road, Fairfield, CA 94585 • Tel. (707) 422-9894
90 Horizon Drive, Suwanee, GA 30024 • Tel. (770) 932-4320
6733 West 73rd Street, Bedford Park, IL 60638 • Tel. (708) 594-5181
2630 North Marine Drive, Portland, OR 97217 • Tel. (503) 240-1980
2400 Tarpley Road, Carrollton, TX 75006 • Tel. (972) 418-2400
N27 W23291 Roundy Drive, Pewaukee, WI 53072 • Tel. (262) 544-1922

ITT Flygt Canada

300 Labrosse Avenue, Pointe Claire, Quebec H9R 4V5
Tel. (514) 695-0100

The originator and world's largest manufacturer of heavy duty submersible pumps and mixers.



www.flygt.com